

All Around Franke

75
Years
Franke

02/2024 The magazine for employees and partners

Franke 2025

Strategy & goals for a secure future

How the company is preparing for the challenges of the future.

Strategy meeting: Departments develop strategies, goals and measures for the future up to 2027.

Plant 6: Current status of construction work, relocations and impressions of the anniversary celebrations.

Innovative: New products and materials for more sustainability and a wider range.

Training & further education: We are getting fit for the demands of the future.

We are ready for 2025



Strategies and goals are defined.



Measures and key figures were developed



Capacity and personnel planning have been completed.



Internal and external processes are established.



< Cover image:
More than almost any other technical product, the robot stand for hightech and future. Its field of application is constantly expanding and creating new possibilities for efficient production. Robotics and Handling ist an important sector for Franke Wire Race Bearings.

“We need people who want to get involved and shape the future.”



Daniel Groz & Sascha Eberhard

Dear employees,

2024 was a challenging year for all of us. In economical terms, we went getting trough difficult times, combined with high investments in our new plant 6, which coincided with a economic crisis. Our performance this year was mixed. We made too little turnover and we had to deal with too many mistakes. The negative developments in incoming orders and the **challenges in the mechanical engineering** in general were clearly noticeable. The fact that Franke can offer secure jobs in these times is a result of our joint efforts and the continious development of our strategy. More on this from page 4 onwards.

Security can no longer be taken for granted today. The world around us is undergoing profound changes: sales markets are changing, global alliances are becoming fragile and social tensions are on the rise. At the same time, we are experiencing increasing armament and radicalization worldwide. As a global company, we are directly affected by these developments - from **security** of our supply chains to the **stability** of our international partnerships and customers.

This is precisely why it is essential that we stand together as a strong team and respont in an agile manner to the demands of an increasingly complex world. **Each and every one of you has an important role to play.** We need people who get involved, who want to shape the future together with us and are willing, to work constructively on improvements. Our jubilees, wo have been with us for many years, are examples of this (see page 28).

We see the coming year as both an **opportunity and an obligation.** We have set the course for success in 2025, but it is up to all of us to follow this path with determination. One thing ist already certain: major changes are coming our way. Plant 6 will be occupied and further relocations will follow. You can read more about this on the pages 14ff.

Let us see the holidays as an oppotunity to recharge our batteries and enter the new year with clear goals and fres energy. We wish you and your families a happy and relaxing Christmas and a good start in a succesfull 2025.

With warm regards,
Franke GmbH

Daniel Groz
Managing Director

Sascha Eberhard
Managing director

Assessment vs. reality

Have our expectations been fulfilled?

In issue 02/2023 we took a look ahead to 2024 and set ourselves goals for the year. The year has passed and we have taken a look at what has become of our plans and how we see the future

Assessment

Reality



1. Sales expectation:

We expected incoming orders to remain weak in the first half of 2024, but were confident that the economy would pick up again by the middle of the year at the latest. In the medium term, we wanted to continue to grow and increase our turnover to € 70 million by 2027.



The expected economy recovery failed and the incoming orders remained weak, which weighed on or sales targets for 2024. Despite the economical headwinds and the investments in plant 6, we were sticking to our medium-term target of € 70 million by 2027.



2. Order backlog:

Our order backlog was increasingly reduced, meaning that our cushion only lasted a few months. Orders of CT bearing in particular were continuously reduced. The situation for bearing elements and guidance systems appeared to stabilize somewhat.



The reduction of the order backlog continued as expected, and our cushion has now shrunk to just a few months. Lucrative projects, particularly in the field of safety technology, are causing the order backlog for special bearing assemblies to rise again.



3. Productivity:

We did not achieve the target of a 5% increase in productivity compared to the previous year in 2023. With appropriate measures, we could be able to increase productivity again in 2024 despite low capacity utilization.



Our cost-cutting measures are having an effect and we have been able to stabilize the situation. Unfortunately, we were unable to increase the productivity.



4. Delivery reliability:

Our delivery reliability was well above 90%. This means that nine out of ten orders reached our customers on the agreed date. That is a very good figure. We wanted to maintain our delivery reliability at this level in 2024.



We were able to maintain our high delivery reliability for the most part and remain at over 90%. This stable performance shows, that our measures are working and that we are serving our customers reliably, even under difficult conditions.



5. Error costs:

The trend in our error costs was downwards. We were in the process of establishing a quality culture in the company. Above all, quality culture means that we follow and adhere to processes, instructions and standards that have been introduced.



The low capacity utilization and the necessary flexibilization have led to an increase in customer complaints. We were able to reduce the error costs slightly. We would like to launch a quality offensive for 2025.

Our expectations for the coming years

Vision Growth 2025 ff

We have managed to significantly increase our turnover in the recent years - a great achievement! Even if we are currently moving sideways, this does not mean, that we are simply drifting along. On the contrary: we want to actively shape the future and

are guided by our mission statement, which serves as our compass. Our vision is to reach a turnover of € 70 million by 2027 as our first major milestone.



Franke is still in an economic crisis. Incoming orders are slowly picking up again and we are seeing the first signs that Franke's business is recovering. The global crises are also clearly noticeable for Franke and we are experiencing a sustainable change in the global market. Franke is also affected by these changes. For the first time, the strategic planning horizon for all departments on October 25 was no longer limited to the financial year ahead, but extended to 2027.

Energy, raw materials and supplies are very cost-intensive, access to markets is becoming more difficult and the competitive situation is intensifying. These challenges must be mastered. Quote from business article in the daily newspaper Schwäbische Post: "Suppliers who want to remain successful in this dynamic situation need to reposition themselves strategically. They need to react in a more agile way, drive innovations with greater focus and customer centricity and also implement this with entrepreneurial risk."

These measures focus on six fields of action:

- Marketing & Sales
- Matrix organization
- Quality & Costs
- Process automation
- Digitalization
- Plant 6 & Relocations

Strategy 2025 ... 2026 ... 2027 ...

Strategy meeting October 25



Franke will achieve a turnover of around € 53 million in 2024. We are currently defining various measures in the different divisions to achieve an increase in sales so € 70 million by 2027.

The increase is necessary in order to fully utilize the company's capacities and be economically successful.

Goal of the strategy meeting: We have developed joint strategies for the next three years and are subsequently coordinating the respective goals, strategic tasks and measures across the specialist areas and within the matrix teams in the best possible way. Our shared vision „**Franke is an agile technology company**“ and **€ 70 Mio. turnover by 2027** are the focus here.

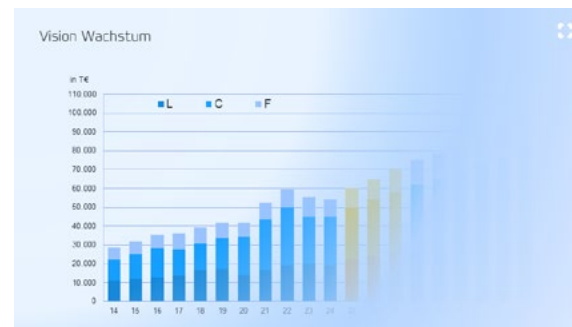

At the strategy meeting, all departments present their goals and priorities for the future. The department goals are based on the company goals. The event was held as a hybrid event, i.e. participants were able to attend live on site or take part via teams. For the first time, trainees also presented their projects as part of the training strategy.



“What strategy is my department actually pursuing?”



This is a legitimate question! The answer is simple: The strategies of all departments can be viewed in the **Franke WIKI**. This is where all departments store their strategy document, in which they describe the direction of the department. All strategies together lead to the company goals being achieved.

In this way, every department and in the end every employee can play an active role in the big picture.

We have summarized the results of the strategy meeting for you on the following pages.

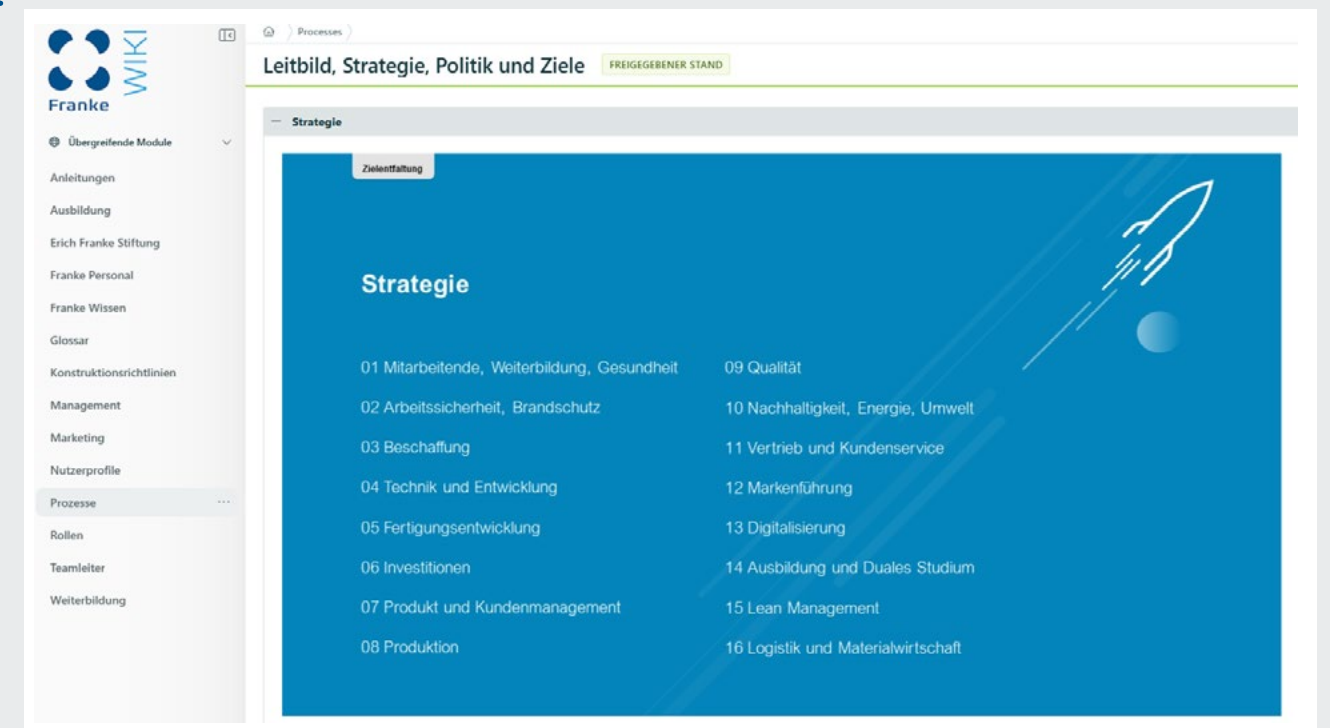

Strategy meeting 2025 ... 2026 ... 2027 ...

Summary of the results

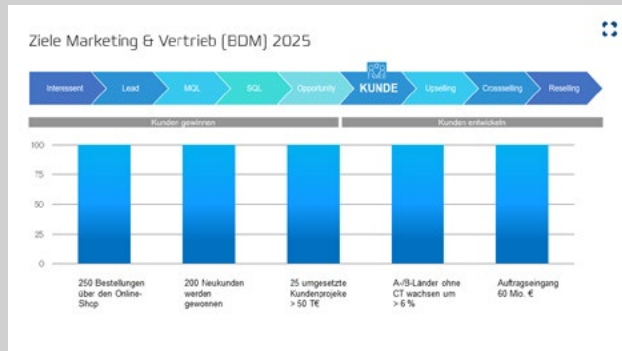

Our goal in **Marketing and Sales** is to secure long-term access to our customer, their applications and markets. To achieve this, we rely on a digital customer approach and a hybrid sales approach as strategic guidelines.

The transformation of the organization and the introduction of digital tools such as CRM (customer relationship management database) and DAM (database for images and media) are in full swing and we are gaining more and more confidence in using them. The task now is to further increase efficiency, productivity and quality.

The textile, CT and safety technology sectors are a particular focus

here. We want to further optimize our internal organization and take a holistic view of the sectors. At the same time, we want to play the market more broadly in order to open up new fields of application and achieve sustainable growth

In order to further optimize our product development processes (PDP), we have carried out a joint strategy comparison in the areas of **production, work preparation, procurement, logistics and quality** and defined coordinated initiatives.

For product groups L, C and F, value stream indicators, projects and measures were defined in a roadmap up to 2027. Our focus topics for 2025 have also been defined. The next step is to work out these topics in detail for each product group and implement them together with the team leaders and group spokespeople from L, C and F.

Another important point is active product streamlining in order to use machines and space more efficiently and thus make our processes leaner and more productive.

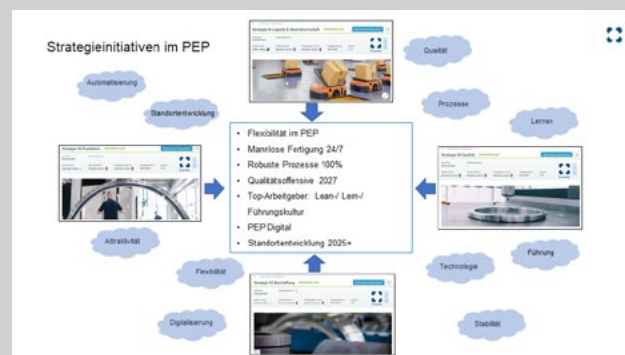

Our **procurement** team has been reorganized and is ready to master strategic and operational tasks in a targeted manner. With Franke Qlik, we now have access to all relevant key figures, including detailed supplier evaluations, and can make decisions even faster. We are currently focusing on second source strategies and cost reduction programs to improve our security of supply and achieve savings.

In future, the selection and qualification of new suppliers is to be documented centrally on a platform so that everyone can access it. We sometimes encounter challenges in this process: The high precision requirements that we place on external suppliers sometimes

even exceed our own standards. Another goal is to organize supplier days - we will work closely with Marketing to plan and carry out these events in the best possible way.

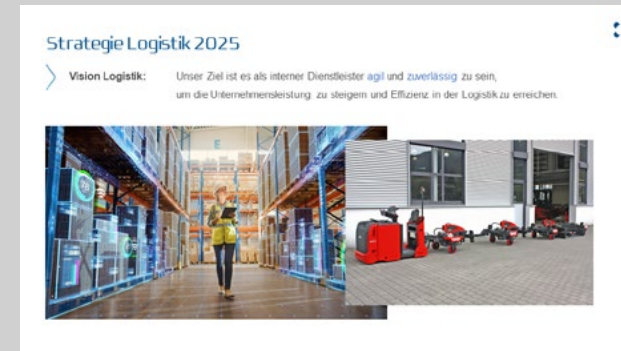

We currently have the greatest to catch up in **logistics**, but this is precisely where we are working together. We want so significantly increase efficiency through process optimization and targeted digitalization. An important point is improving the quality of packaging so that our products arrive safely and flawlessly at the customer.

With external support, we are raising the export controls to a high level in order to meet the requirements of the safety-critical industry. Our logistics has a clear vision: we want so drive forward automation and modernisation and thus gradually create high-performance, future-proof logistics.

In **quality management**, we are currently facing the challenge of overcoming the highest complaint rate of the recent years. Our focus is therefore on quality management, process capability and stronger supplier management. A first step is to review the accuracy requirements of our turned parts and adjust them if necessary. Our 'Service' department is now firmly established and relieves sales, production and other areas by taking on numerous tasks.

At the same time, professional handling of errors is becoming increasingly important. **Errors in themselves are not a problem - the problem is how we deal with them.** This is precisely where we want to improve significantly in order to learn from mistakes and ensure sustainable quality

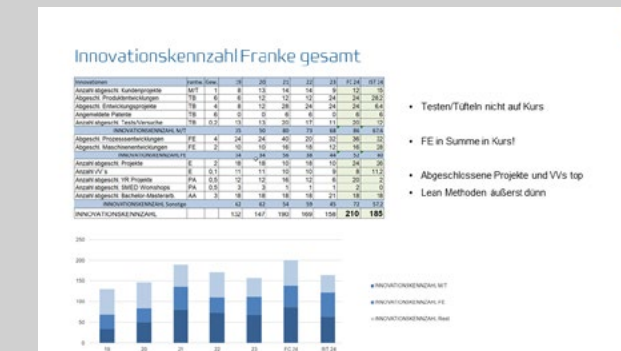
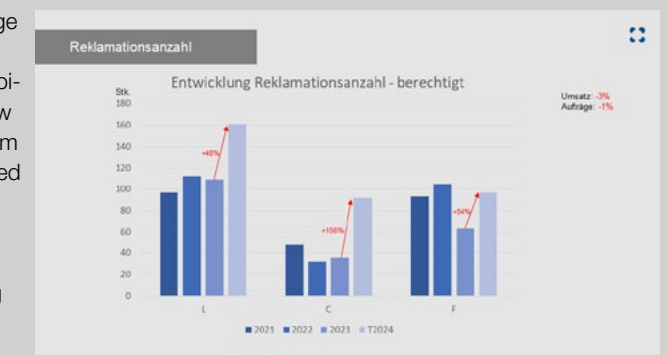

Innovation is the core of our brand - but only a few of the **designs and developments** of recent years have made the leap to become real sales drivers. It is therefore important to thoroughly analyze tops and flops and derive measures where necessary. We are particularly successful where we have a clear customer application in mind - customer centricity is the key!

At the moment, however, testing and tinkering only take place to a very limited extent, which we would like to expand. Obstacles include the limited capacity in the technical center, as prototypes and complaint processing take priority here, as well as the lack of physical proximity to the FE, which makes collaboration more difficult. These challenges need to be addressed in order to fully develop our innovation potential.

Strategy meeting 2025 ... 2026 ... 2027 ...

Summary of the results



We are making good progress in **production development**: our preventive maintenance and machine and process developments are largely on track for 2024, and many good ideas are contributing to the current target achievement of 80%.

The organization via TopDesk is working increasingly smoothly and clear management of maintenance and production development is visible. Our strategy has been adjusted only slightly and we have already defined a roadmap for organizational development, machines and processes as well as testing projects until 2027.

Our **Digital & IT** team now works in a very coordinated manner and we use synergies effectively to make the best use of our IT resources. Step by step, we are establishing an IT management system to manage our facilities in the best possible way. IT security remains a central focus: in 2025, we will have to invest further in this area in order to meet both the legal requirements (NIS2) and the current threat situation - anything else would be entrepreneurially negligent.

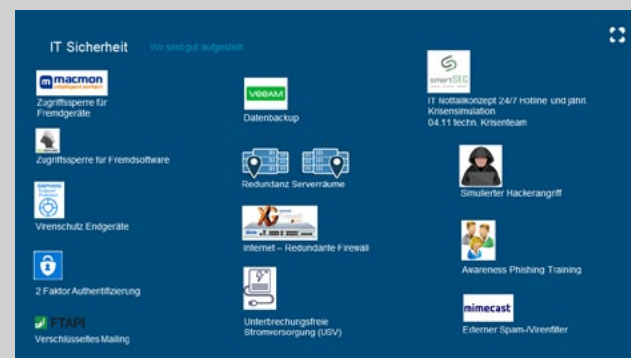

Digital project management is being reorganized so that we can manage our digitalization projects even more efficiently. In addition, an investment quota for IT security and a benchmark comparison will be determined.

Konzentration aufs Wesentliche

Was brauchen wir an Systemen? Personal & Learning

- Projekt wird durch AE durchgeführt
- Personalprozesse analysieren & Bedarfe (Lastenheft) ermitteln
- Bestehende Systeme nutzen

Impulsverträge als Anreize zum intrinsischen Lernen

- Netzwerk Hochschule, SoftWear/Metal usw. nutzen
- Mitarbeiter einbeziehen

Lernzeiten - Qualifikationsverhalten korrigieren

- Lernen während der Arbeit (Lernmodule entwickeln)
- Darüber hinaus Prozesse schaffen

Führungskräfte befähigen & unterstützen

- Muss vorgelebt werden

Lernende Organisation

Eine lernende Organisation entwickelt kontinuierlich Wissen und Fähigkeiten, um sich den Veränderungen in der Umgebung anzupassen und ihre Ziele effizienter zu erreichen.

We still have some catching up to do in **training** in 2024 and have achieved 36% of our target. The basic processes have now been established and our priorities for 2025 are in place - now we need to implement them consistently. Regular strategy meetings of the 'Academy' are crucial here.

Our **shoulder glances** were revived this year and are very popular. We see great potential here to strengthen cooperation and create a better understanding of each other. (You can find practical examples on page 30).

In the area of **training and studies**, on the other hand, we are on track with a target achievement of 90%. The training quota is rising continuously and the training professions are being constantly developed. Despite a reduced budget, we are implementing targeted marketing measures. In addition, we are expanding the opportunities in administration to include areas such as service, QM and HR.

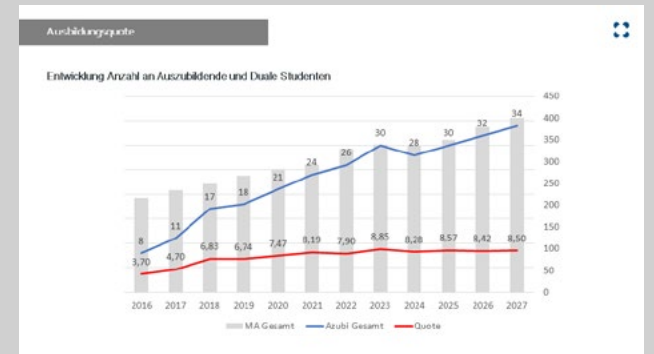

In order to give trainees guidance, rules and guidelines are being improved and we are examining potential professions of the future. The aim remains to further increase the proportion of trainees in the commercial sector.

Ziele 2025

bis 2027 gleichbleibend

- wir erzielen die Unfallquote 0
- wir erreichen eine Risiko-Quote 100
- wir erreichen die CO₂-Neutralität
- wir reduzieren Stromverbrauch um -> 5%
Neues Ziel: wir reduzieren jährlich den Stromkonsum/Umsatz um 5%
- wir reduzieren Abfälle um -> 5%
Neues Ziel: wir reduzieren jährlich die gefährlichen Abfälle/Umsatz um 5%

Our strategic focus in the area of **sustainability and the environment** remains unchanged, and we currently have a target achievement rate of 77%. The areas of fire protection, occupational safety, energy, sustainability and the environment work with an established system of key figures that gives us a good overview of the current status. Strategically, we will focus on emissions from our suppliers in the coming years and have taken the first steps to reduce emissions from our purchased parts as well. We are also setting up a comprehensive energy monitoring system to enable us to manage our resource consumption in an even more targeted manner.

In **work preparation**, the focus is on delivery reliability. We are not yet on track here. A decisive lever for improvement is the precise planning and control of our orders. Our activities - from organization and employee training to system expertise, master data and KPI analyses - are aimed precisely at this.

Fokus 2025

Soll-/Ist-Vergleich

Maßnahmen:

- Aufbau MIS
- Wöchentliche Sitzung
- Meldeprobleme lösen
- Vereinfachung der Auswertung

Erwartete Wirkung:

- Verbesserung Ertrag
- Verbesserung Durchlaufzeit
- Vorbereitung auf digitale Kalkulation

The roadmap to 2027 shows the most important topics, with the focus areas for 2025 clearly defined: Start optimizer, target/actual comparisons, bottleneck analyses, digital costing and organizational improvements in the CT warehouse area.

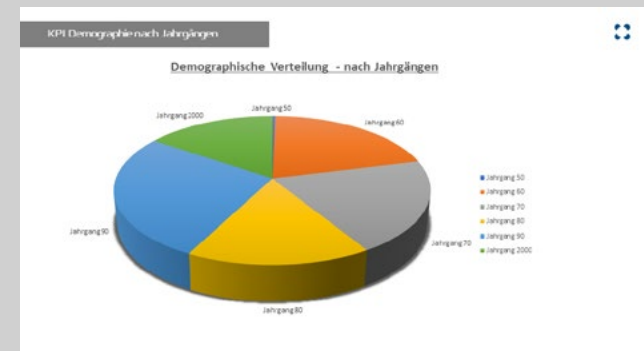

We have now built up an effective system of key figures in the **HR area**. As a service provider, we focus on the needs of the specialist departments. The age structure in the company is well balanced and shows a balanced mix of all age groups.

We are currently discussing how we can reduce the sickness rate and promote a positive mentality. After 18 months of crisis management, we want to address these issues more intensively again. We are also planning a "Quality Day" for 2025 to promote exchange and strengthen collaboration.

” In workshops at measure level, we determine how we want to achieve our goals for the area in 2025. The goals of all departments then contribute to achieving the corporate goals.

Marketing team



Strategy 2025 ... 2026 ... 2027 ...

Measures & target development

Your contribution makes the difference!

At Franke, we have a common plan: our brand values and goals are the guidelines for our strategies, key figures and ultimately the measures that affect us all. We call this the target development process. What really counts is the commitment of every employee - for example in defining the measures.

Everyone - whether at the machine, at the computer screen or in contact with customers - can contribute with their ideas and their daily work to help us achieve our corporate goals. Together we can achieve great things! Get involved, make suggestions and help us move Franke forward. Your commitment makes the difference!

Target achievement
Current status as a notice in the Franke Portal

Strategy
Franke WIKI under mission statement and as a document

Department goals
Franke WIKI or target document in teams

Key figures, KPIs
Shopfloor, ReKo, various evaluations and documents

Methods and measures
In the Franke WIKI under methods

Mission statement

Principles

What do we work for?

We want to make a difference: technical innovations, the development of personal potential and the development of good human relationships.

How do we work?

We support our clients in every phase of the collaboration with our creativity, expertise and diligence.

What do we do?

We develop and produce ideally suited bearing solutions for rotary and linear applications - including consulting, engineering and service.

Brand values



Agility



Competence



Innovation



Reliability



Team spirit

Mission

With our invention of the wire race bearing, we help our customers to be innovative.

Vision



Franke ist an agile technology company.

Target development

Goals



- We are economically successful.
- We work together.
- We act sustainably.
- We are digital.
- We are innovative.

Strategy

- 01 Employees, training, health
- 02 Occupational safety, fire protection
- 03 Procurement
- 04 Technology and development
- 05 Production development
- 06 Investments
- 07 Product & customer management
- 08 Production
- 09 Quality
- 10 Sustainability, energy, environment
- 11 Sales and customer service
- 12 Marketing
- 13 Digitalization
- 14 Training & dual studies
- 15 Lean management
- 16 Logistics and materials management

Departmental goals

- Academy & Training
- Work preparation
- Procurement
- Digital & IT
- Production development
- Production
- Lean Management
- Quality Management
- Sustainability, occupational safety, environment, energy management
- Marketing & Sales
- Logistics
- Human Resources & Finance
- Technology & Development

Key figures, KPI

- P&L, earnings, profitability, investment ratio, liquidity
- AE, turnover, delivery reliability, lead time, productivity, error costs
- No. of leads, no. of customers, export share, customer satisfaction, no. of complaints
- Innovation indicator
- Customer projects, new customers, patents, R&D ratio
- Personnel costs, training
- Digitization indicator
- Lean, VR, SMED, FME, ...
- Inventory turnover, purchasing index, inventory, second source, supplier evaluation
- Number of employees, personnel costs, training, sick leave, vacation, flexitime, overtime, subsidies, degree of flexibility
- CO2, refurbishing, commitment
- Digitization index
- Accidents, risk, electricity, waste
- Site development

Methods, measures

- Strategy conference & site assessment
- Project Management
- Lean Management
- ReKo, Shopfloor
- CIP
- FMEA, QFD
- VV management
- Shoulder view
- Further training
- Mentoring
- Volunteering

Plant 6

Anniversary celebration & inauguration

On September 27, we celebrated the inauguration of our new Plant 6 with around 200 employees - a historic moment for Franke and also the largest investment in the company's history.

The management took the opportunity to recapitulate 75 years of successful company history, which is now being continued in this new production facility. A special highlight was the visit of Gerhard Groz, our former Managing Director, who played a decisive role in the development of Franke. The mayor of Aalen also gave us his best wishes for the future in his welcoming address.

A big thank you to the organizing team who made this celebration possible, and of course to everyone who attended and made this day a special moment.



^ A look at the dimensions of the new hall: the large buffet and the 200 guests almost got lost in the enormous space.

< Greetings from the mayor. The city of Aalen presented a framed construction plan of the first production hall to mark the company's 75th anniversary.



< Motifs from the anniversary book were displayed on information boards as a journey through time. You can also find the entire company history online at: www.franke-history.de/en



^ Former Managing Director Gerhard Groz (pictured right) was the guest of honor at the event. He had a significant influence on the development of the company between 1976 and 2007.

> The Franke trainees were also there, actively helping in the organization team and having fun at the party.



Location development

Plant 6 / Relocations

The relocations will be divided into various phases and are expected to take up a large part of the 2025 financial year. On the one hand, the duration will be influenced by conversion and refurbish-

ment measures in areas that will initially be vacated before they are reoccupied. On the other hand, we must ensure that our customers notice as little as possible of the relocation activities.

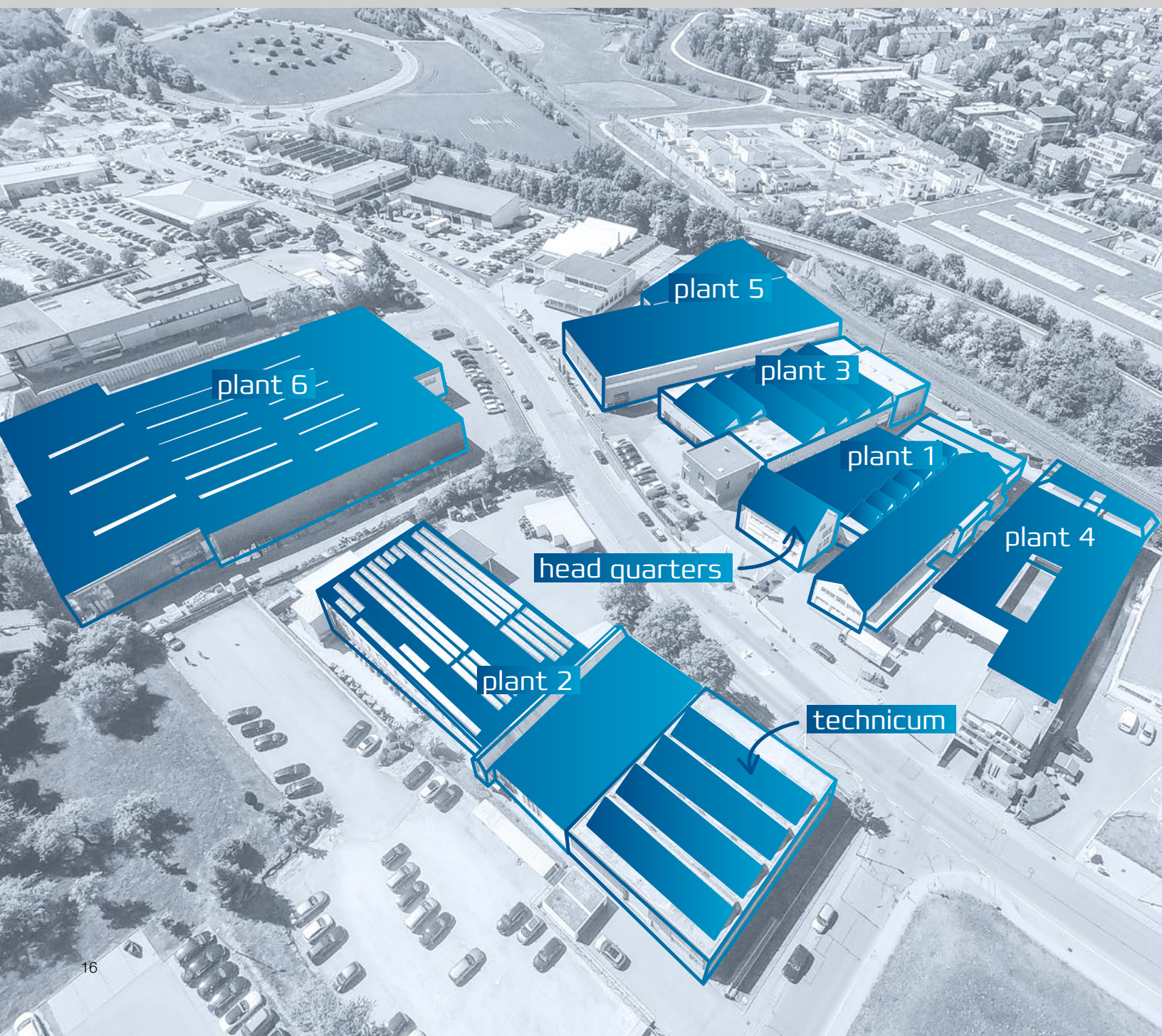

A relocation project of this size involves opportunities and risks. Risks can arise due to weather conditions, for example - if there is black ice, large-scale transportation by road cannot take place. Opportunities arise when things go faster than planned - in this case, follow-up activities can also be brought forward. This means that there is a very high probability that there will be changes to plans during the removals, to which we will respond.



Before we start with the respective relocation, the teams on site are informed personally and in detail. Any final questions can also be clarified here.

The individual steps should be completed by then:

	<p>Production:</p> <p>Linear guides:</p> <ul style="list-style-type: none"> Production remains in Plant 3 with a new layout. A new rolling-in machine is installed <p>Bearings for computer tomographs:</p> <ul style="list-style-type: none"> Production moves from Plant 5 to 6, including the prototypes and the DMU210. <p>Wire Race Bearings</p> <ul style="list-style-type: none"> Cutting, straightening & grinding (CNC) move from Plant 1 to Plant 5. The rolling division moves from Plant 1 to the logistics building in Plant 5. Conventional production will be consolidated in the grinding shop in Plant 1. The RM 7 rolling machine will also be located there. <p>Bearing assemblies:</p> <ul style="list-style-type: none"> Machining production will move from plant 2 to plant 5. Assembly will be realigned in the entire Plant 4. 	<p>JANUARY</p> <p>MARCH</p> <p>JUNE</p>	
		<p>Administration:</p> <ul style="list-style-type: none"> Sales & Marketing move from the administration to the new office space in Plant 6. The matrix for Product Group C is given workstations in the new office space in Plant 6. Personnel move to a separate area in the former Marketing office space. The Quality / Service department moves to the Sales department and is thus directly connected to the Design, Procurement and Work Preparation departments. 	<p>JUNE</p> <p>AUGUST</p>
		<p>Production development / training / technology</p> <ul style="list-style-type: none"> Maintenance and equipment construction move from plant 4 to the technical center and plant 2. The technical center is expanded and given more space. The entire FE and maintenance team moves together into offices in Plant 2. Training is given more space 	<p>SEPTEMBER</p>
	<p>Warehouse / Logistics</p> <ul style="list-style-type: none"> The warehouse area is given additional space in the wire race bearing production area in plant 1. A storage area for the dispatch logistics of finished CT bearings is being created in Plant 2. 	<p>SEPTEMBER</p>	

Production

New machines increase capacity

With the acquisition of the DMU 125 and a state-of-the-art Zeiss coordinate measuring machine, we are significantly strengthening our production capacities in Plant 6. The DMU 125 is equipped with a 12-pallet changer and enables us to manufacture efficiently and flexibly. It is complemented by the new Zeiss coordinate mea-

suring machine, which has an impressive measuring range of 2x2 meters and can also precisely inspect large workpieces. These investments are an important step towards meeting the increasing demands of our customers and further optimizing the quality of our products.



Adapting capacities to our sales targets and designing the layouts for the new infrastructure are major challenges for production planning. But it's precisely these tasks that motivate me and ultimately make my job so appealing.

Daniel Lindenlaub, Deputy Production Manager

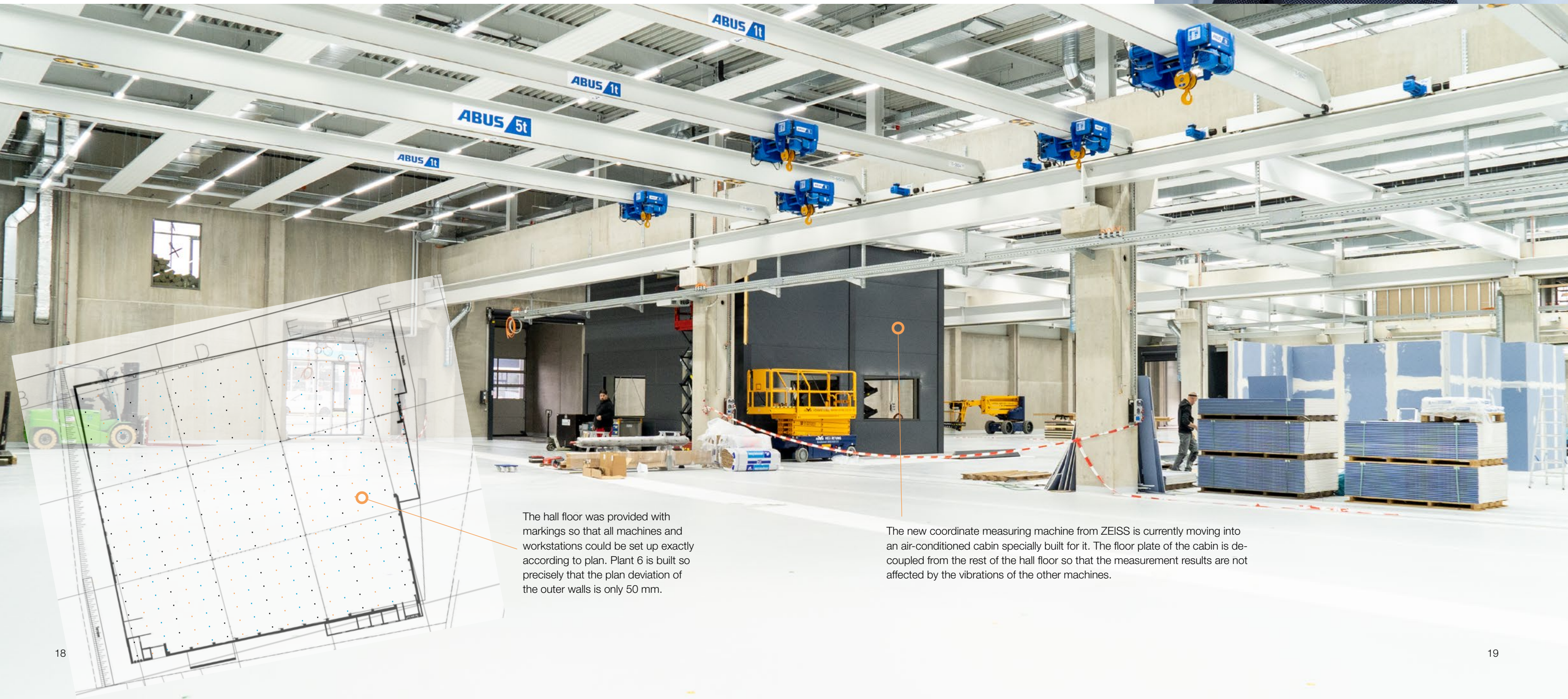

The hall floor was provided with markings so that all machines and workstations could be set up exactly according to plan. Plant 6 is built so precisely that the plan deviation of the outer walls is only 50 mm.

The new coordinate measuring machine from ZEISS is currently moving into an air-conditioned cabin specially built for it. The floor plate of the cabin is decoupled from the rest of the hall floor so that the measurement results are not affected by the vibrations of the other machines.

75 years of customer satisfaction

Customer survey

A recent survey of our A and B customers shows: We are on the right track! The positive feedback confirms that our consistent customer focus, which has characterized us for 75 years, is bearing fruit. Satisfied customers are the best sign that our daily

work is well received and appreciated. The survey results motivate us to continue on this path and to always give our best in close cooperation with our customers.

Brand image from the customer's perspective:

Our brand image continues to evolve. We have been conducting these customer surveys at regular intervals since 2010. During this time, our image among customers has changed. Franke is now increasingly perceived as progressive and innovative.

2010 / 2015 / 2021 / 2024

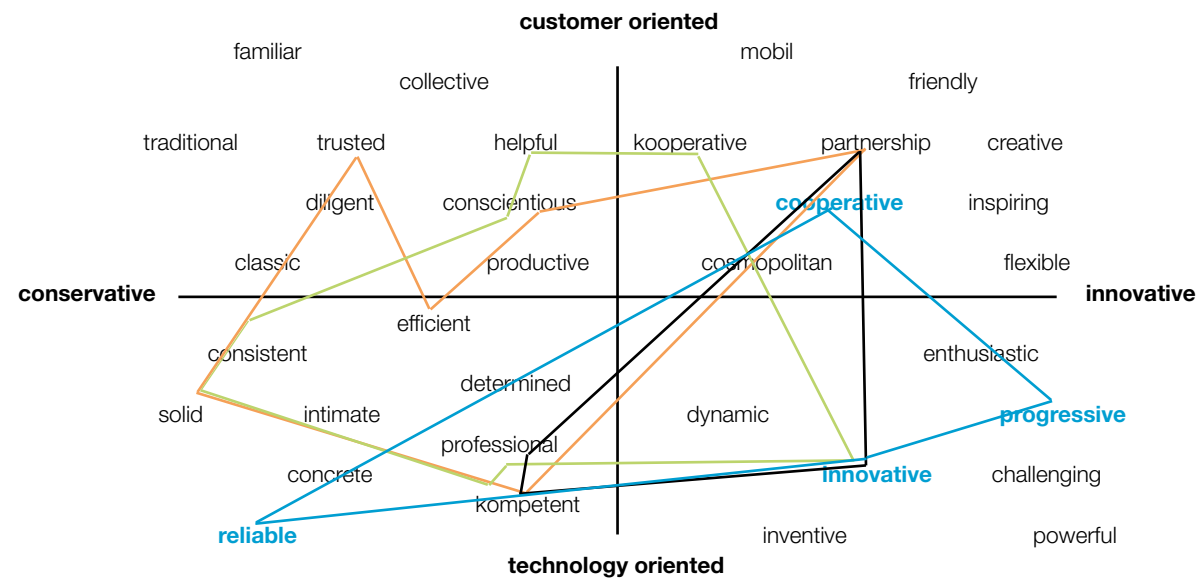

Service:

Delivery times are currently our weakest point. Sustainability is becoming increasingly important and we are already well positioned here. The online store is well known, but is not yet being used adequately.

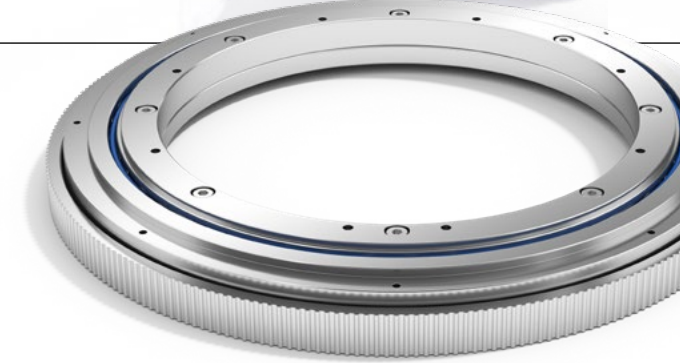
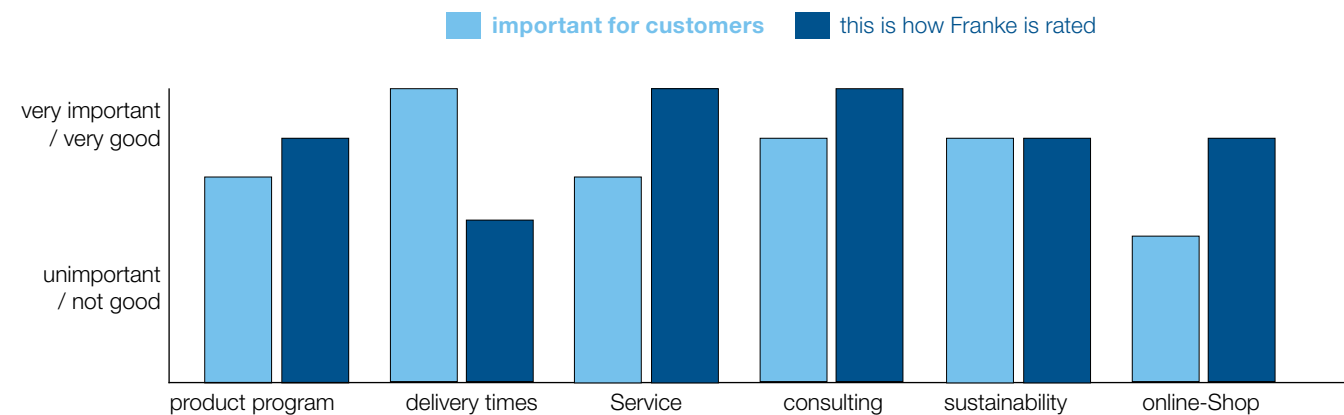

Bearings:

Precision, resilience and freedom from maintenance are the most important customer requirements. With the exception of freedom from maintenance, we are very good here. Lightweight construction and drive systems are less important, but our image is very good in both cases.

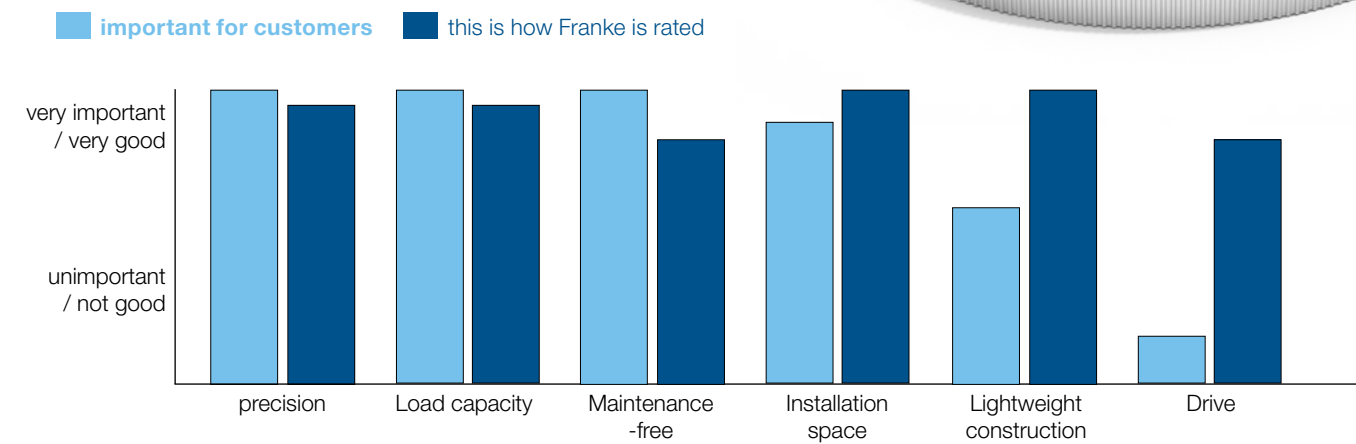

Linear Guides:

When it comes to smooth running, freedom from maintenance and freedom from lubricants, our customers are not yet familiar enough with our performance. We are very good when it comes to dynamics and lightweight construction. Measuring systems do not yet play a role, but seals do.

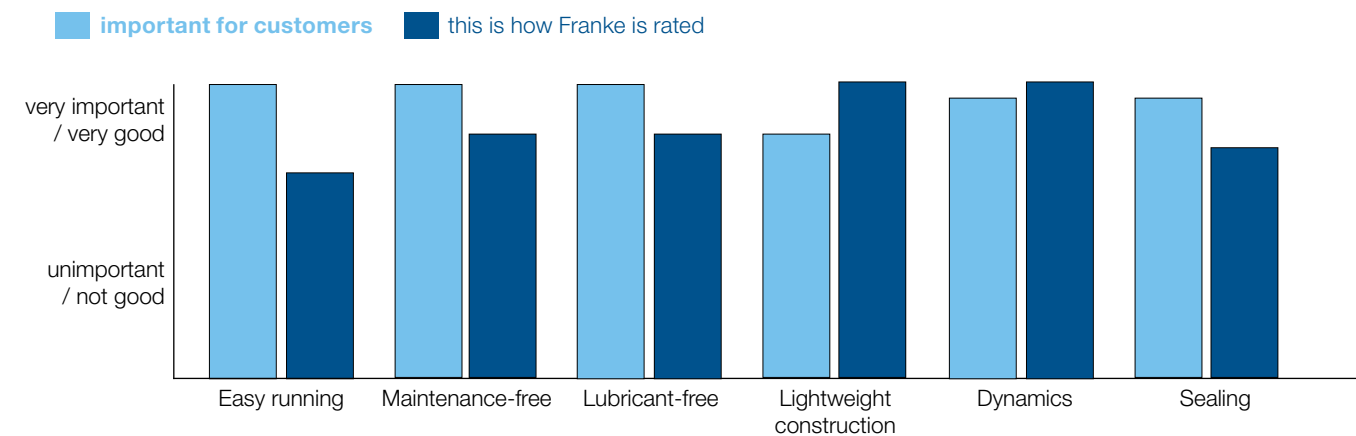

Innovations Products & Applications

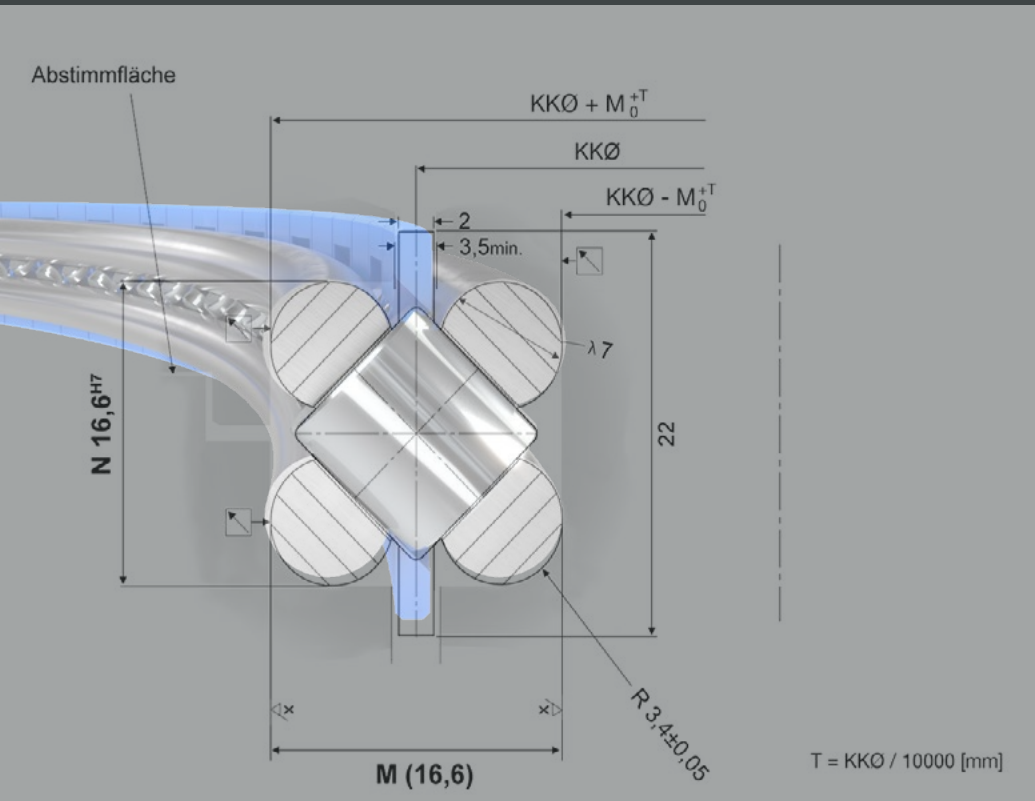

NEW: Wire Race Bearings LEW 4

Franke wire race bearings with cross rollers (type LEW) are particularly suitable for medium rotational speeds and accuracies. They impress with their smooth running, high rigidity and compact installation space.

The crosswise arranged rollers absorb equally high loads from all directions. Bearing elements of type LEW are robust and insensitive to shocks and vibrations. They have balancing properties for demanding load types. Due to the linear contact, the rotational resistance remains constantly low - even in uneven load situations.

Now the LEW series has a new addition: the new LEW 4 impresses with its particularly compact installation space of just 16.6 mm in height and width.



Quality and responsibility: Innovative technologies for our safety

The development and production of components for security technology is undoubtedly a sensitive issue - especially at a time when there is a great desire for peace and stability. At Franke, it is important to us that our products make a significant contribution to security and defense.

Our Wire Race Bearings are not only technical masterpieces, but also an expression of our commitment to the highest quality and reliability.

We can be proud of the craftsmanship and engineering skills that we apply every day to manufacture these sophisticated products. Because at the end of the day, it's all about protecting people and ensuring safety so that a peaceful life is possible in the first place.

Defense and security technology is one of the most technically demanding and dynamic industries in the world. Components used in this industry must meet extremely high safety and performance requirements and are often exposed to adverse conditions such as high loads, changing temperatures and constant vibrations. In this environment, where precision and reliability are of the utmost importance, every element in the system is a critical component - this is especially true for rolling bearings.

Rolling bearings are essential components in defense technology and are used in numerous applications: from optical systems and radar systems to rotary mounts and drive systems. In radar systems, for example, they enable precise positioning and tracking, which is necessary to accurately locate enemy objects. In military vehicles, they ensure the efficient movement of turret superstructures, which can be moved safely and accurately despite enormous weight loads.

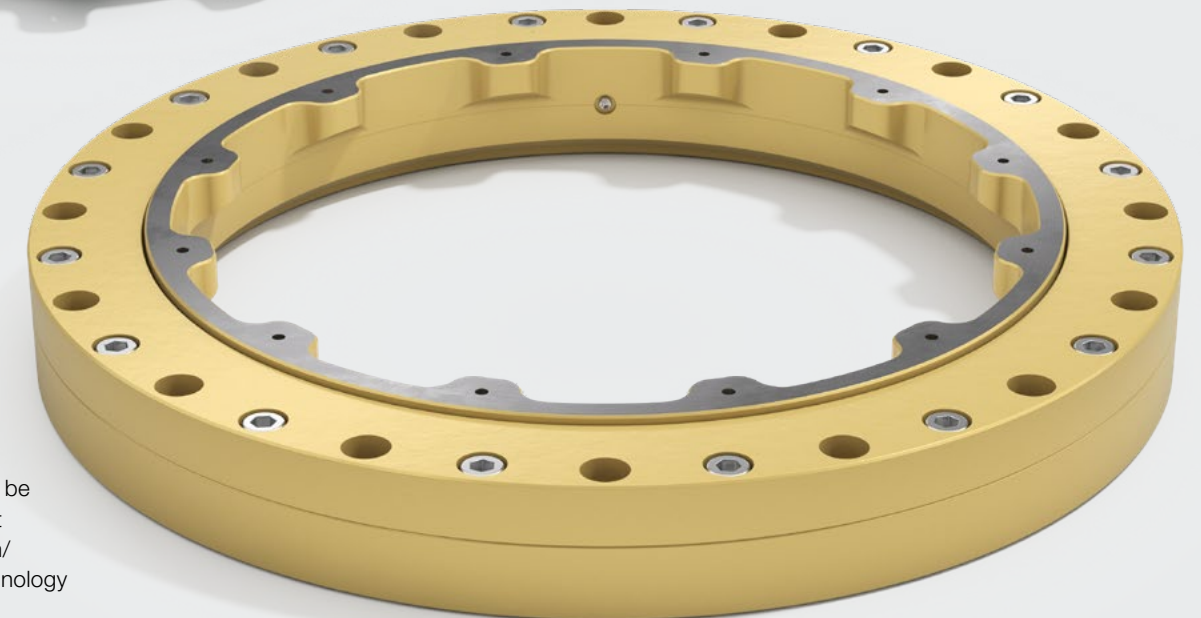

Further information can be found on our website at www.franke-gmbh.com/industries/defense-technology

Sustainable materials

We rely on secondary aluminum

Since 2024, we have relied entirely on secondary aluminum, especially for our linear guides. Primary aluminum is aluminum that is extracted directly from the raw material bauxite - a process that consumes a lot of energy.

Secondary aluminum, also known as recycled aluminum, is produced from previously used aluminum material such as old beverage cans or car parts. This aluminum is melted down and recycled. The recycling process is very energy-efficient, saves resources and reduces waste.

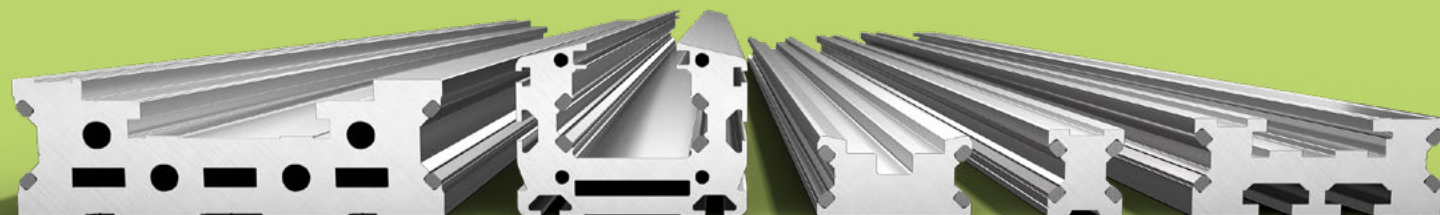

Movie shoot Franke WIKI

On September 18 and 19, 2024, the company Modell Aachen visited us. Modell Aachen is the developer of Qwiki, the software on which our Franke WIKI is based. Modell Aachen brought along a group of interested new customers to demonstrate the power of Qwiki using a practical example. The group was given an insight into Franke WIKI in the form of presentations at the meeting point and a tour of the company.



^ Video shoot in the Digital & IT department

For us, the video shoot was a valuable opportunity to present our company as a pioneer in digitalization and efficient knowledge management.

The production of this film will benefit us in the long term: Modell Aachen will use the video as a customer story and thus make our innovative approaches accessible to a wide audience. This not only raises our profile, but also strengthens our position as a modern and future-oriented company.



Marketing for Franke too!

The film highlights how the use of Qwiki allows us to optimize our internal processes and effectively bundle the knowledge of our teams - a plus point that will appeal to potential new customers and specialists alike. Another benefit is the visibility and reach we gain through this collaboration: The film allows us to authentically show our commitment to digitalization and process optimization and offers interested professionals and partners the opportunity to get to know our company even better.

Many thanks to everyone involved for their good work behind and in front of the camera, which made this project possible!



^ Filming a sequence during ring production

Your Works Council We stand together!



Dear colleagues,

2024 began quietly, but the workload increased significantly towards the end. The flexibility you all show is of great value - thank you very much for that!

We took important steps in the area of **health** in 2024. With our partnership in the EGYM Wellpass company fitness network, you have the opportunity to do something good for your health at low cost - 88 of you are already taking advantage of this offer!

In addition to physical health, mental health is also important to us. Andreas Neubauer and I have completed **Mental Health First Aid** (MHFA) training to provide support in this area. If you or your colleagues notice any signs of mental stress, we are here to help. If you prefer external help, Karolina Tomanek, our company chaplain, is there for you.

At the end of the year, we would like to thank Marcel Lorenz for his dedicated work as Chairman of the **Youth and Trainee Council**. During his term of office, the JAV was restructured: The committee now consists of three people in order to do justice to the increased proportion of young people in our company. Many thanks for your commitment, Marcel, and good luck to the new JAV team!

We wish you a relaxing holiday season and a happy new year and a healthy and successful 2025. - *We are Franke!*

Gabriele DiNucci
Chairman of the Works Council

Parking tag

A parking tag is enclosed in this all-round edition for all active employees. It serves as an identifier for the authorized use of the parking spaces. This is to ensure that the parking spaces remain reserved exclusively for Franke employees and unauthorized parking is avoided.

We would therefore ask you to attach the parking tag to the rear-view mirror of your vehicle so that it is clearly visible every time you park in the parking lot.

Thank you very much!

We would like to take this opportunity to appeal to you once again to use the parking spaces behind Plant 2 and not to park in Obere Bahnstraße. This will make it easier for us to transport materials from one side of the road to the other. - Thank you very much!



New colleagues A warm welcome!



Stefanie Hejlek

is deployed as an employee in procurement.



Lukas Rautenberg

supports production in the machining department in Plant 2.



Tatjana Powelleit

joins the commercial sales team.



Simon Rathgeb

works in plant 4 in the LD assembly team.



Ernest Andrzej Wojtyczka

supports production in Plant 5 as a separator.



Andrej Tomm

joins the machining team in production at Plant 2.



Marleen Kaufmann

is a new employee in the machining department in Plant 5.



Setche Ore Polycarpe Atchadé

has been completing an internship in the Marketing department since September and is supporting the introduction of a DAM system ("pixxio"; image database) at Franke.

May June July August September October November



Jannik Sachsenmaier

started in the Digital & IT department as a system administrator.



Nadine Scholz

has started in the procurement department.



Larissa Hoffmann

is employed in the office of the Logistics & Shipping department.



Abdul Rahman Koroma

works in production in the assembly CD of plant 5.



Johann Kautz

supports production in Plant 2.



Lukas Blümle

has started as a new employee in the FE department.



Alexandra Tauscher

started in the Finance/Accounting department.



Matthias Bühlmaier

has started in plant 4 in assembly LD.



Martina Sedó

from Spain is an acquaintance of Ignacio Garcia (Spanish representative) and has been visiting Germany since November for an internship at Franke in the Technology & Design department.

We are delighted about the fresh wind and hope that the two of them will be able to take away many instructive and positive experiences from their time at Franke!

Reliable over many years

Jubilees 2024



This year's anniversary celebration at Villa Koepf provided an opportunity to recognize the achievements of these valuable employees. In his speech, Daniel Groz emphasized: "Our long-standing employees are irreplaceable pillars of our company, especially in challenging times like these. Their identification with Franke, coupled with a high level of commitment and the willingness to go above and beyond the call of duty, are the keys to our continued success."

The jubilarians by length of service:

- 5 years:** Meike Reifschneider, Daniel Barth, Maurice Henne, Waldemar Hochhalter, Sandra Ramona Schichta, Florian Kurz, Jolante Matusch, Doreen Grässle, Thomas Schwarting, Tobias Wieland, Nina Allgaier, Konstantin Pelz, Pia Albersmeier, Matthias Allgaier, Svenja Sarah Brunnhuber, Kai Samuel Kratschmann, Marcel Lorenz, Marcel Rosner, Ghasem Amoozegar
- 10 years:** Sven Mück, Michael Schenk, Niklas Schwarzer, Richard Schwab
- 20 years:** Atidze Butic, Matthias Neufischer, Holger Baumann, Andreas von Wrangell, Stefan Szymanski, Viktor Martin
- 25 years:** Sandra Pietsch, Nicola Gentner, Artur Metzger, Heiko Kaschdailewitsch, Thomas Winter, Stephan Kuhn, Alexander Schmidt, Jens Wanner
- 30 years:** Oliver Schröder, Markus Bieg
- 40 years:** Klaus Mayer



Obituary Fikreta Basic

Wir mourn for our former colleague. We cherish their memory.



Farewell...

All the Best!

 Have a good time in well-deserved retirement!



Karlheinz Waldenmaier

is taking his well-deserved retirement after 37 years. He remained loyal to Plant 2 throughout his career. As a lathe operator on the CNC machine, he produced a wide variety of turned parts. Back then, Mr. Waldenmaier was still hired with a handshake and experienced the change from conventional machines to working on CNC machines at first hand. Even in retirement, he remains active: his grandchildren and the tug-of-war club keep him busy, and he also devotes himself to 3D printing.



Harald Müller

joined us in 2005 as a CT straightener and later moved to Plant 5. He spent his last three years back in the LE area in Plant 1. With Mr. Müller, we are bidding farewell to our "model straightener" as he enters his well-deserved retirement. There is hardly anyone in the company whom he has not thoroughly trained in straightening activities in the LE and CE areas. He played a particularly important role in the successful introduction of the P46 bearing - without his commitment, we would never have implemented this project at this speed. The bearing remains a cornerstone of our success in the CT business to this day. Mr. Müller can now devote himself to his hobbies in peace: the garden, the shooting club and his grandchildren.



Erich Morenweiser

started as a team leader in mechanical production in October 2010. Even back then, he impressed with his specialist knowledge, his pragmatic way of thinking and his Bavarian composure, which was particularly helpful in stressful situations. In 2018, he moved to the Quality Assurance department, where he was responsible for test equipment management. With his commitment to quality, good ideas and sense of humor, he made a valuable contribution to Franke. In his newly gained time in retirement, he can now devote himself extensively to his garden, tend to it and then, of course, relax there!

Team spirit

Shoulder glances

The Shoulder Glances campaign is intended to provide an insight into the working methods and work content of colleagues and offer the opportunity to get to know them better. Participants spend a day visiting a team of their choice. They are released from work on this day. All employees at Franke can take part in a Shoulder View once a year in almost every department. Read here about the experiences of our colleagues with the "Schulterblicken" program in the company

Are you interested in gaining an insight into the daily work of another team? Then you will find all information for easy registration in the Franke WIKI under: Organize Shoulder Views. We look forward to your participation!



”

As part of the "Shoulder Glances" campaign, I took a day to gain a comprehensive insight into the strategy and tasks at Franke **Marketing**. My colleagues gave me an insight into their interesting, extensive and modern working day. The Shoulder Glance was divided into different areas of responsibility and I was shown who in the team is responsible for which topics and tasks and to what extent they work together. I would definitely recommend this kind of shoulder glance!

Daniel Faulhaber - Digitalization & IT



”

I carried out the "shoulder glance" in the **PL, PF, T and Q** departments, as I didn't have a direct run-through in the company. This gave me the opportunity to gain a deeper insight into the tasks and activities of the individual departments. It was particularly exciting for me to observe the different processes in the various product groups.

I was able to understand the construction of our products, in some cases according to individual customer requirements. I also had the opportunity to observe and actively participate in the manufacturing process of our products. In quality assurance, I experienced how precisely the incoming goods, intermediate and final inspections and the processing of complaints are carried out in order to guarantee the high quality standards.

The insights into the various specialist areas helped me to better understand our procedures, processes and products. I can recommend the "Shoulder Glance" to anyone who is interested in getting to know other departments and developing a deeper understanding of the various company processes.

Lamprini Terpsiadou - Human Resources

”

I did a Shoulder Glance in the **accounting department** to understand working methods and processes, to strengthen communication and cooperation and for my own development and further training.

The department took a lot of time to explain the processes and background to me in detail, which has given me a much better understanding of the specific working methods and processes. Each of my questions was answered in detail and several travel expense reports were processed as part of the current travel expense management project. This clearly showed the need for a travel expense accounting tool that offers significant savings potential in terms of time and resources.

Thomas Schibelgut - Digitalization & IT



”

I had the opportunity to do a Shoulder Glance in the **LE production department (rolling, cutting, grinding)** for one day. My aim was to gain interdisciplinary insights beyond my own area of responsibility and to broaden my knowledge horizon. I was able to better understand the production processes and grasp their significance in the overall context of the company. I particularly appreciated the excellent support and the hands-on approach, which gave me valuable practical experience.

My conclusion: A Shoulder Glance is really worthwhile and is highly recommended for anyone who wants to broaden their perspective!

David Meyer - Digitalization & IT



Projects

Franke Next



Interdisciplinary training project: Investigation of the tilting rigidity of our LV series

This summer, Kilian Sturm successfully completed his training as a technical product designer with us. Even during his training, he dealt with the topic of tilt rigidity - a key concern for our customers, who regularly have questions about the tilt rigidity of our products. Supported and guided by Markus Güttlin, he continued this topic as part of a practical project. Together they determine the tilting rigidity of our LV series. The aim of the test is to become more meaningful for our customers.

Deniz Kocaöz from the second year of the industrial mechanics apprenticeship was brought in to give the apprentices the opportunity to play an active role. By dovetailing the technical center and training, Kilian had the opportunity to share his experience. This collaboration offers trainees the chance to work on real projects and take on responsibility.



^ Deniz Kocaöz (Apprentice industrial mechanic, le.) und Kilian Sturm (Technical product designer, ri.)



Junior Innovators: Company within the company

As part of the "Junior Innovators" program, our trainees have the opportunity to realize their own ideas and actively shape the innovative strength at Franke. This "company within the company" concept gives them the opportunity to develop projects independently and create solutions for real challenges - from concept to implementation.

The trainees are supported by their trainers. They learn how to work with new ideas and in teams. This makes them more self-confident and teaches them more about new ways of working.

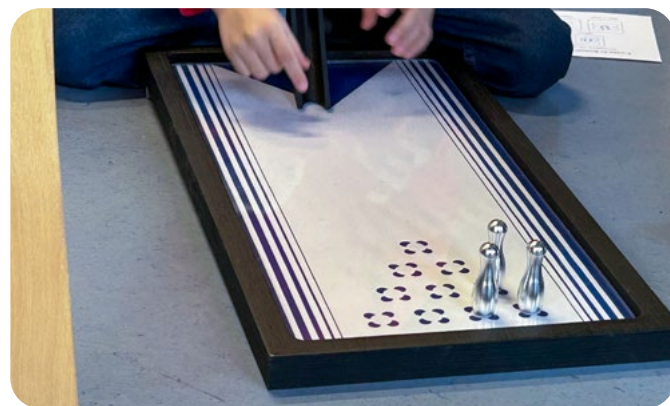

Bowling alley

The bowling alley was a project that we designed for the children at the Zochental daycare center. Many things had to be taken into account, such as the size of the skittles and the balls, as they had to be perfectly matched.

Many different steps were necessary for the bowling alley. The starting ramp was printed using a 3D printer, the base was made of wood and colored, and a plexiglass sheet was placed on top.



Make 'N' Break

The Make ,N' Break game was also a project specially designed and produced for the event with the Zochental daycare center. The building blocks were manufactured in the training workshop and then anodized to give them a high-quality look and color.

The tasks and the corresponding cards were also conceived, designed and cut out completely independently.

News

A warm welcome

We are delighted to welcome 10 new trainees to our company this year.

Industrial trainees joined us:

Felix Fischer (industrial mechanic), Maximilian Gruber (industrial mechanic), Max Tschürtz (industrial mechanic), Goran Stamenkoski (industrial mechanic), Collin-Bo Dorsch-Hering (Cutting machine operator), Clemens Raab (Cutting machine operator)

Commercial trainees joined us:

Iordana Terpsiadou (Industrial clerk), Christina Medyk (Industrial clerk), Luk Wittmann (IT specialist)



Congratulations on your graduation!

A total of 5 trainees at Franke have successfully completed their training this year. We are delighted that four of them will remain with us as employees in the various departments!



Kilian Sturm

creates detailed technical drawings as a technical product designer.



Linda Flottmann

actively support our logistics as an industrial clerk.



Jule Launer

brings her creativity to the marketing team as a media designer.



Lukas Giesert

is an IT specialist and your contact for all technical and digital issues.

Events



DKMS Penalty Cup

On June 22, a company football tournament took place with the motto "Kicking blood cancer to the ground together!". The Franke trainees were also represented. In addition to playing soccer, over 100 new registrations were collected for the German Bone Marrow Donor Center.



Future Day

On July 13, we had our Future Day. There were insights into the training workshop and the plants. The trainees also gave presentations about their apprenticeships and dual study programs. The Future Day took place in cooperation with the Bierschneider car dealership and Mapal.



Tug of war contest

On October 7, we took part in Alfin's apprentice tug-of-war contest. In teams of eight, we competed against trainees from companies in the surrounding area. It was a successful day that was a lot of fun despite the rainy weather!



Kita Zochental

On October 31, we had some very special guests with us: the children from the Zochental daycare center! We introduced them to our products and then played some of the games created and produced by our trainees (more on page 33). We played other games that our trainees had also developed themselves on October 29 when we visited the daycare center.

Students



AIM Aalen

Our team was once again represented at the Aalen Industry Fair at Aalen University and had many good discussions with interested parties and provided insights into possible career opportunities at Franke:

- Practical semester:** Learn from our professionals and gain valuable professional experience.
- Work-study program:** Earn money and expand your skills while studying.
- Thesis:** Find the ideal topic for your Bachelor's or Master's thesis with us.



Our students introduce themselves

Felix Sauter



Area: Logistics
At Franke since October 2024

What are you studying?
Industrial Engineering and Management at Aalen HS (Bachelor)

What do you like about Franke and what is your job?
I like my team, the flexible working hours and the support for my studies. I'm writing a bachelor's thesis on the subject of product packaging.

Why did you choose Franke?
I am very interested in the subject of product packaging and I have heard consistently positive things about Franke so far, and this positive impression was confirmed in the interview. Another advantage is the short distance to my home and the Aalen HS.

Hannah Lauber



Area: Marketing
At Franke since Juni 2024

What are you studying?
Business Development at Aalen HS (Master)

What is your job?
My job is to select and set up a suitable digital asset management system for Franke. I also support the marketing department with other upcoming tasks.

Why did you choose Franke?
I chose Franke because it gave me the opportunity to gain an insight into a different area and gain new experience. Franke is also very close to my university and my home town. The flexible working hours as a working student are also very helpful during my studies.

Johannes Deeg



Area: Engineering & Development
At Franke since September 2024

What are you studying?
Mechanical Engineering Production & Management at Aalen HS (Bachelor)

What is your job?
I am currently writing my bachelor's thesis on the influence of seals on rotational resistance as a function of different parameters.

Why did you choose Franke?
I have only heard positive things about Franke from people I know and found the topic interesting for my Bachelor's thesis.

Nico Kratschmann

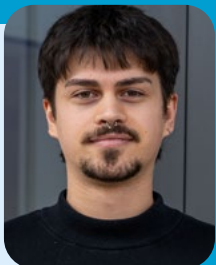

Area: Production
At Franke since Oktober 2024

What are you studying?
Product development and manufacturing at Aalen HS (Master)

What is your job?
I support the programming department in creating the set-up plans in the WinTool tool management system.

Why did you choose Franke?
I successfully completed my bachelor's thesis in collaboration with Franke. I also really liked the company during my stay.

A contemplative time **Have a Merry Christmas!**



Take time for yourself!

Just grab a few colored pencils and color the mandala! Coloring mandalas is a type of meditation that can help you focus on your thoughts or simply switch off for once.

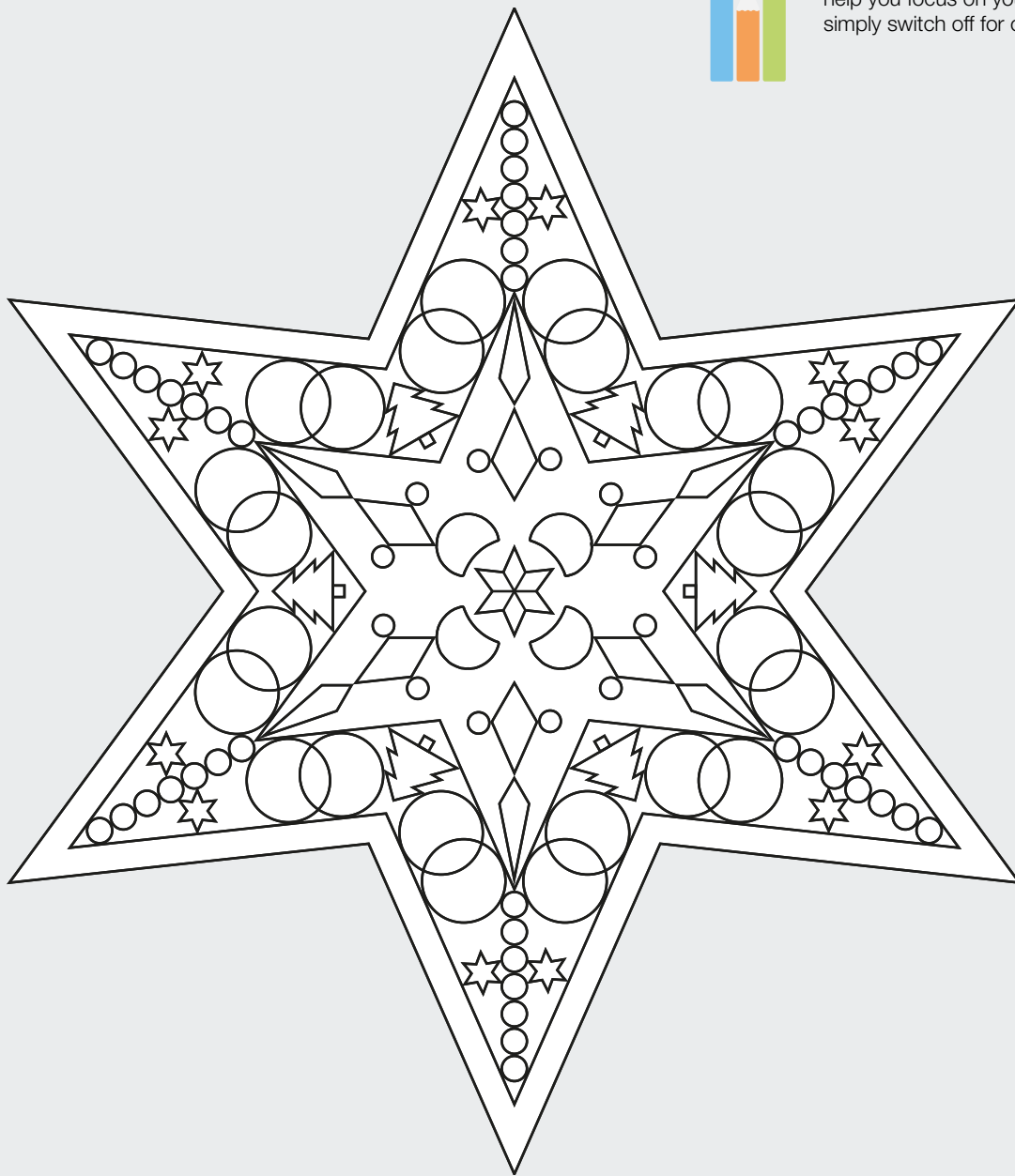

Publisher:
Franke GmbH
Obere Bahnstraße 64
73431 Aalen

Contact:
Tel. +49 7361 920-0
info@franke-gmbh.de
www.franke-gmbh.com
www.franke-history.com

Responsible:
Gerhard Reiningger
Public relations
Franke GmbH

Design:
Franke GmbH, Aalen
Print: ce-print, Metzingen
All right reserved.

Photo credits:
Adobe, Shutterstock,
Canva, Getty Images,
Privat, Franke

